

LM111 - Military / aerospace  
LM211 - Industrial grade  
LM311 - Commercial grade

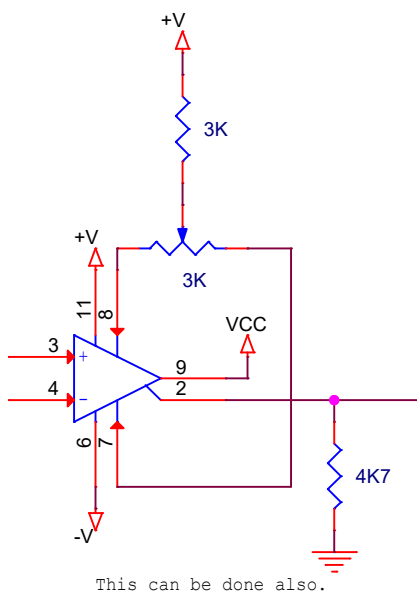

The output is an NPN transistor with both the emitter and collector available. Pin 9 is the collector. Pin 2 is the emitter.

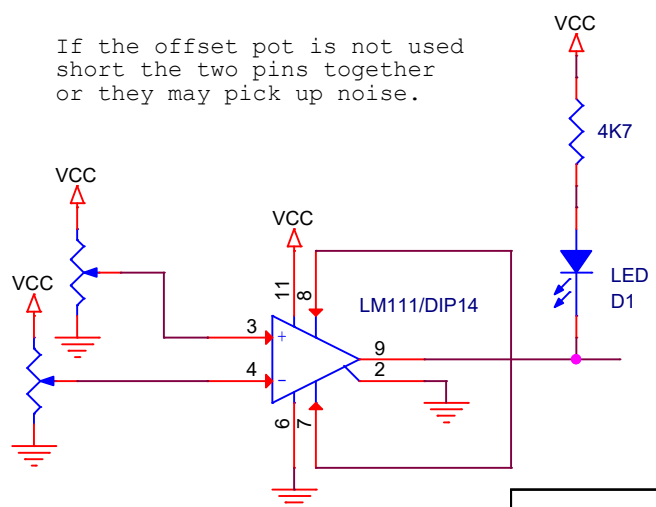

Title		
LM111 14-pin DIP		
Size	Document Number	Rev
A	Design 1790	1
Date:	Monday, April 05, 2021	Sheet 1 of 1